

Introduction to Argumentation Systems

Victor DAVID



DIPARTIMENTO
DI MATEMATICA E INFORMATICA

Argumentation: stakes

- A model of reasoning based on the need to justify.
Essential for deciding, convincing, explaining, ...
- A multidisciplinary theme
 - **Artificial Intelligence** [Loui (1987), Pollock (1987)]
 - Philosophy [Aristote, Toulmin (1958)]
 - Psychology [McGuire (1960)]
 - Linguistics [van Eemeren et al. (1996)]
- Examples of applications
 - **Medical**: argumentative diagnostic support system
 - **Legal** : argument-based decisions on the law
 - **Online debate systems** (e.g. DebateGraph, Debatepedia, idebate, ProCon)
 - **Conflict resolution systems** (e.g. CyberSettle)

Argumentation in AI: process

Different issues (e.g. decision-making, classification, negotiation, ...)

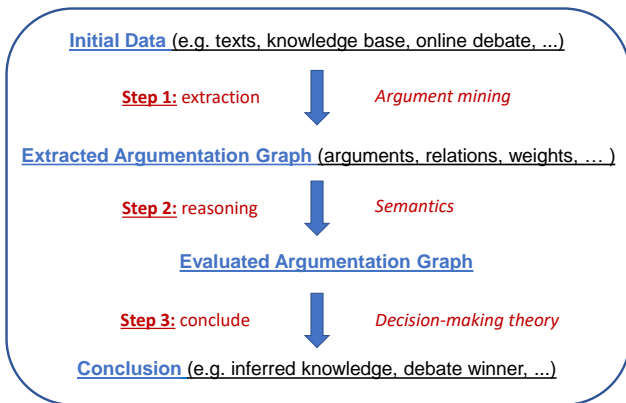

Decision-Making in Argumentation (Step 1)

Textual Database

- i1 = The mushroom has a good smell.
- i2 = Generally (80% of the cases) mushrooms with a good smell are not poisonous.
- i3 = It seems that the mushroom smells like almonds (40% certainty).
- i4 = A mushroom that smells like almonds is a mushroom defined as having a good smell.
- i5 = The mushroom was found in a damp place.
- i6 = A mushroom found in a damp place can be poisonous (60% of the cases).
- i7 = The mushroom was found in a place where it has recently rained.
- i8 = When a place is damp but it has recently rained, it is possible (50%) that the place was not damp before the rain.

Extracted Probabilistic Bipolar Argumentation Graph

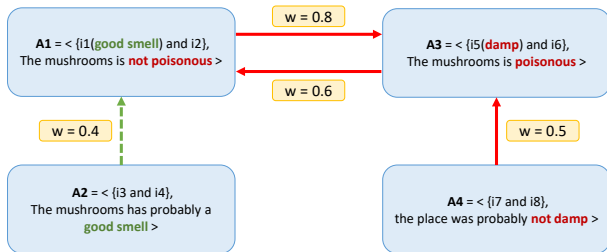

Decision-Making in Argumentation (Step 2)

Extracted Probabilistic Bipolar Argumentation Graph

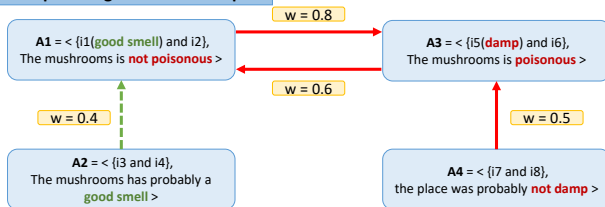

Evaluated Probabilistic Bipolar Argumentation Graph

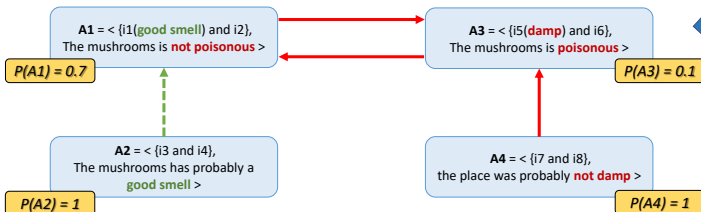

Semantics

Decision-Making in Argumentation (Step 3)

Evaluated Probabilistic Bipolar Argumentation Graph

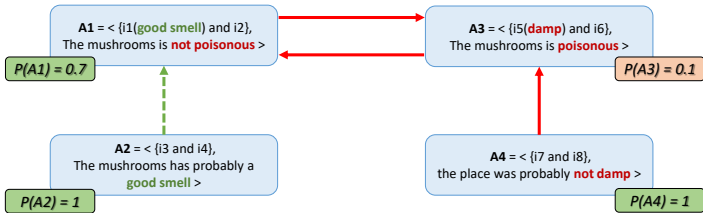

Conclusion

- The mushrooms has probably a good smell and was not in a damp place
- The mushrooms is not poisonous (0.7)

Process of Probabilistic Semantics

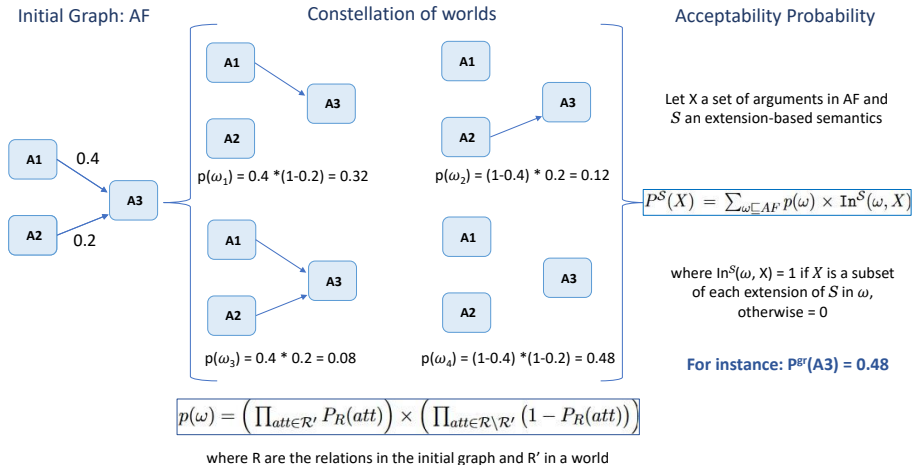

Complete Semantics

Complete Semantics

$$L : A \rightarrow \{\text{in}, \text{out}, \text{und}\}$$

in = **accepted**, out = **rejected** and und = **undecided**

1. $L(A) = \text{in}$ if and only if $|L(\text{att}) = \text{in}| < |L(\text{def}) = \text{in}|$ or $|\text{att}| = 0$
2. $L(A) = \text{out}$ if and only if $|L(\text{att}) = \text{in}| > |L(\text{def}) = \text{in}|$
3. $L(A) = \text{und}$ if and only if $|L(\text{att}) = \text{in}| = |L(\text{def}) = \text{in}|$ or $|\text{def}| = 0$ and $L(\text{att}) = \text{und}$

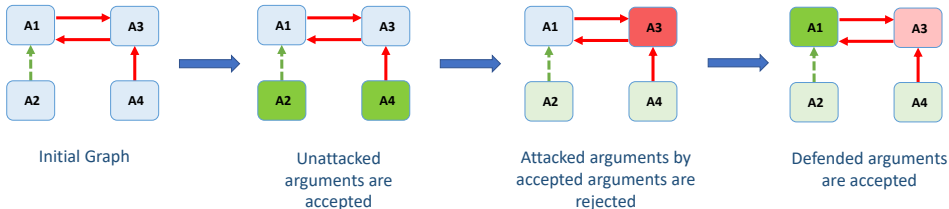

Extensions

Complete Semantics

3. $L(A) = \text{und}$ if and only if $|L(\text{att}) = \text{in}| = |L(\text{def}) = \text{in}|$
or $|\text{def}| = 0$ and $L(\text{att}) = \text{und}$

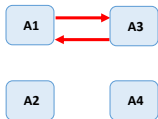

Initial Graph

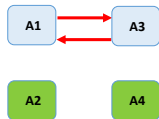
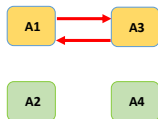
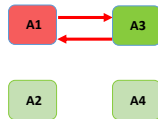
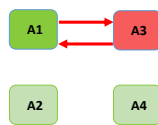
Unattacked
arguments are
accepted

Extensions

Constellation

Constellation

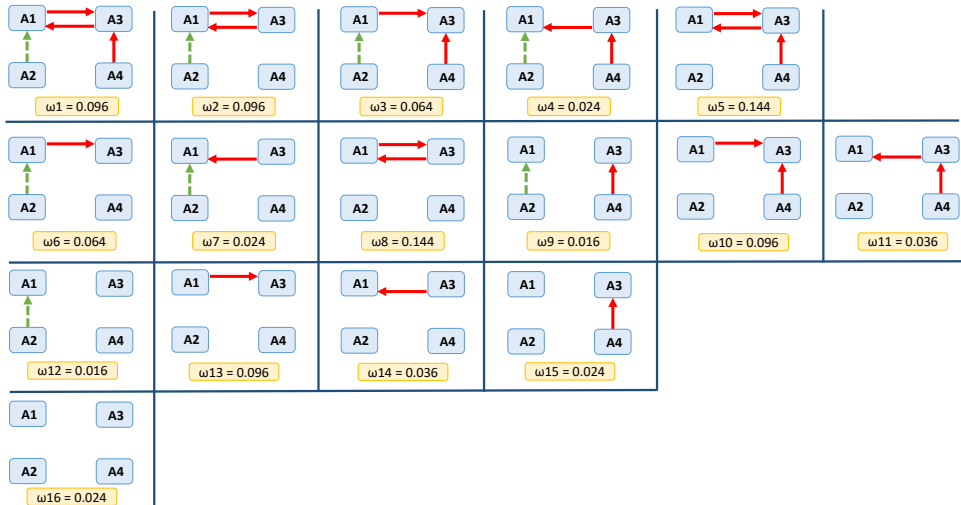

Acceptability Probability of A1 with Complete Semantics

Constellation

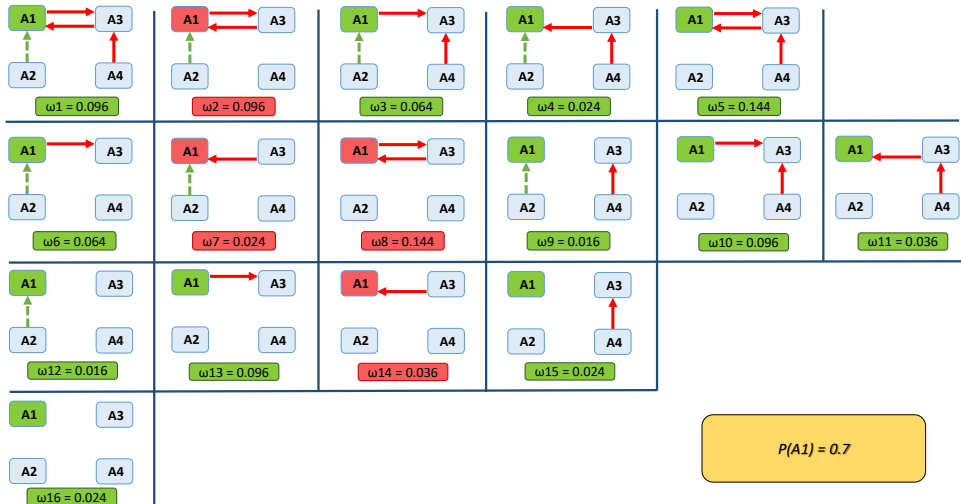

Example with Probabilistic Complete Semantics

Extracted Probabilistic Bipolar Argumentation Graph

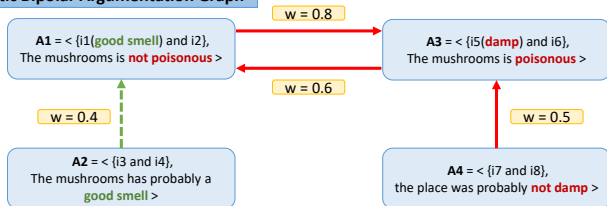

Probabilistic Complete Semantics

Evaluated Probabilistic Bipolar Argumentation Graph

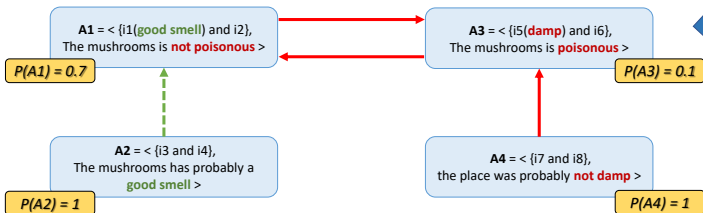

Explanation from an Evaluated Argumentation Graph

Evaluated Probabilistic Bipolar Argumentation Graph

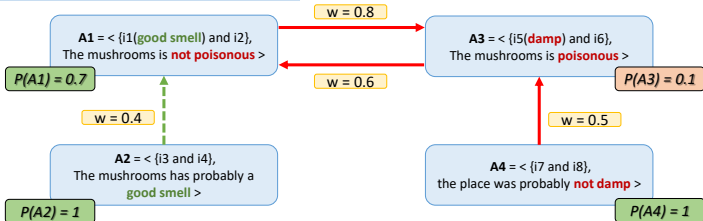

Conclusion

- The mushrooms has probably a good smell and was not in a damp place
- **The mushrooms is not poisonous (0.7)**